

DM1100 2C EVO

/ DOUBLE-SIDED EDGE ROUNDING MACHINE

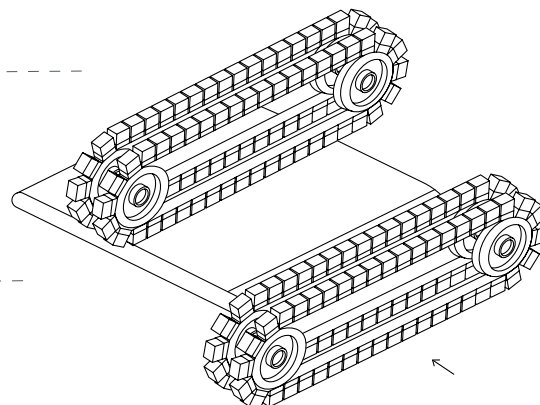

DEMONSTRATION VIDEO



OVERVIEW

__ One solution for all parts: double-side edge rounding of parts longer than 150mm and single side of parts from 50x50mm

__ Processes simultaneously both sides of metal sheet parts cut by laser or punching machine, saving time and reducing operation costs

__ Integrated touch screen panel for monitoring the working settings and the machine alarms

__ Touchscreen panel for machine control, remote process monitoring, operation statistics and alarms overview

TECHNICAL SPECIFICATIONS

| | |
|------------------------|----------------|
| working capacity (mm) | 1100x50 |
| feeding speed (m/min.) | 0.6-3.2 |
| crossbelt speed (m/s) | 2-8 |
| crossbelt motor (kW) | 3 (4x) |
| total power (kW) | 13 |
| consumption (A) | 30 |
| dimensions (mm) | 2000X2590x2150 |
| weight (kg) | 2470 |



__ easy and tool free cross belt replacement

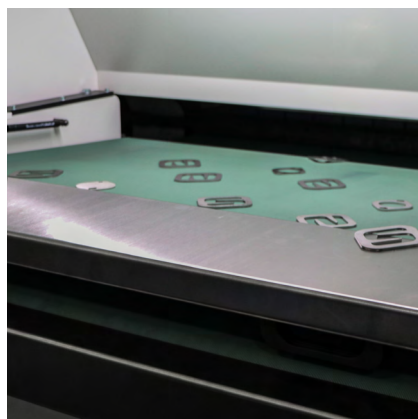

__ single-sided process for parts as small as 50x50mm thanks to on additional conveyor and support table



__ after DM1100 2C EVO: high performance on all edges and also on internal holes