

# DM1100 C

/ EDGE ROUNDING MACHINE

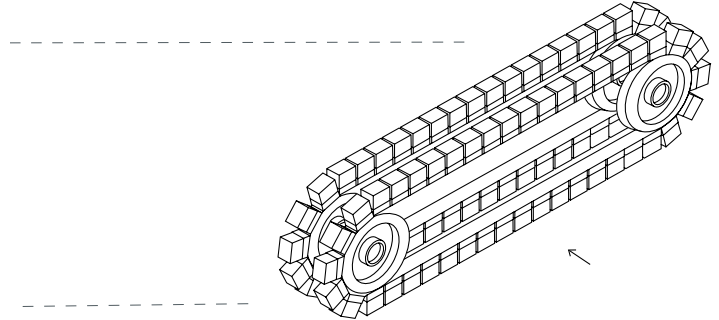

## DEMONSTRATION VIDEO



## OVERVIEW

\_\_ Two abrasive crossbelts operating in opposite directions, completing edge rounding in every corner of the part

\_\_ Strong edge rounding on parts down to 50x50mm

\_\_ Easy setup and swift operation

\_\_ Parts return system improves productivity on small parts or double sided operation (option)

## TECHNICAL SPECIFICATIONS

working capacity (mm)	1100x50
feeding speed (m/min.)	0.6-3.2
crossbelt speed (m/s)	2-8
crossbelt motor (kW)	3 (2x)
total power (kW)	6
consumption (A)	11
dimensions (mm)	2230x1510x2040
weight (kg)	1350

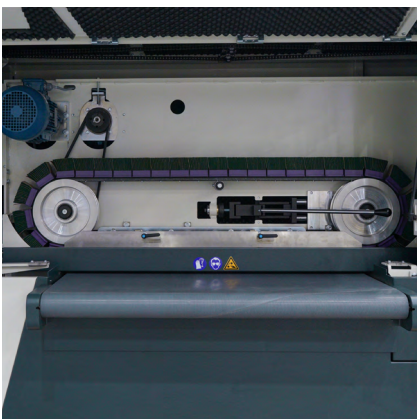

\_\_ 2 counter-rotating cross-belts

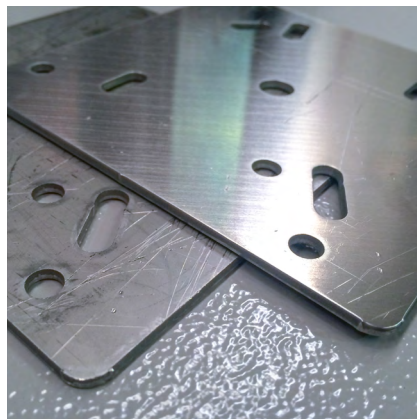

\_\_ stainless-steel part before and after edge rounding



\_\_ parts as small as 50x50mm can be easily rounded on this machine