

# DM1100 C EVO

/ EDGE ROUNDING MACHINE

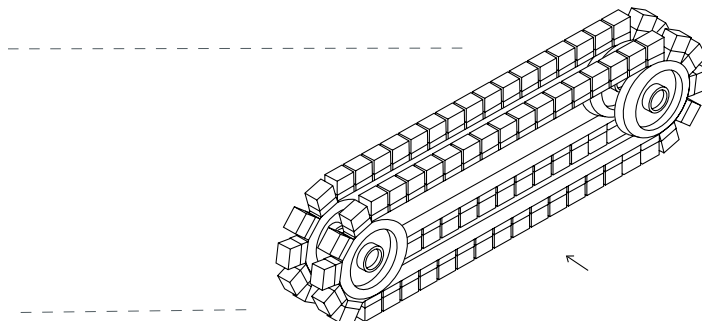

## DEMONSTRATION VIDEO



## OVERVIEW

\_\_ Two abrasive crossbelts operating in opposite directions, completing edge rounding in every corner of the part

\_\_ Strong edge rounding on parts down to 50x50mm

\_\_ The machine can be equipped with loading and unloading conveyors, thus allowing for more buffering capacity and reducing the need for the operator to be constantly moving around the machine

## TECHNICAL SPECIFICATIONS

working capacity (mm)	1100x50
feeding speed (m/min.)	0.6-3.2
crossbelt speed (m/s)	3-8.1
crossbelt motor (kW)	3 (2x)
total power (kW)	6.5
consumption (A)	16
dimensions (mm)	2300x1550x2040
weight (kg)	1400

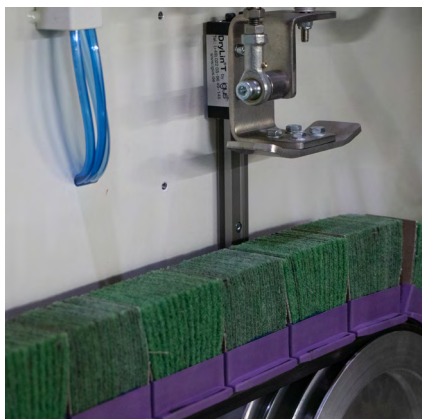

\_\_ 2 counterrotating cross-belts with automatic abrasive wear compensation



\_\_ touchscreen panel for machine setting with motorized adjustments, parameters storage and bar code reader

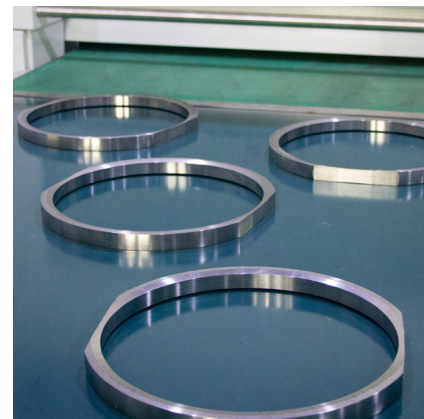

\_\_ buffering capacity with the integration of automatic loading and unloading tables