

DM1100 ZC

/ DEBURRING AND EDGE ROUNDING MACHINE

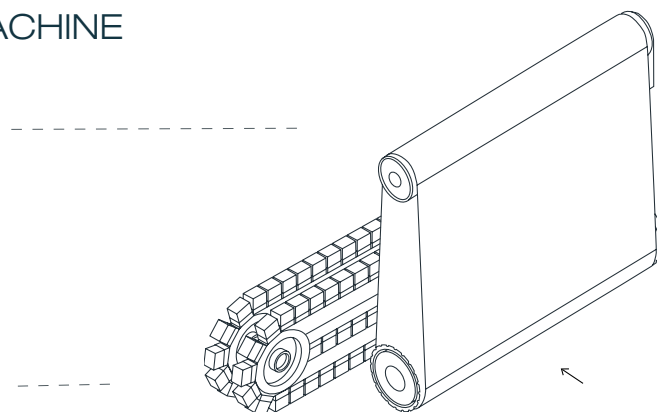

TECHNICAL SPECIFICATIONS

working capacity (mm)	1100x120
feeding speed (m/m)	0.6-10
abrasive belt speed (m/s)	8-22
crossbelt speed (m/s)	2-8
feeding motor (kW)	0.37
abrasive belt dimensions (mm)	1100x1850
abrasive + crossbelt motor (kW)	11 + 3 (2x)
consumption (A)	29
dimensions (mm)	1880x2180x2080
weight (kg)	2050

DEMONSTRATION VIDEO



OVERVIEW

__ The abrasive belt station has a large diameter contact roller with Ø186mm diameter and 55SH, allowing for both deburring and finishing operations

__ Quick manual reset of abrasive blocks wear

__ Improving the productivity on small parts with one single operator

__ Simple adjustments integrated on the machine for a quicker, more intuitive and reliable thickness and pressure



__ the compact size takes less floor space and it's easier to operate while delivering the same top-quality deburring and edge rounding



__ physical buttons provide a simple and intuitive way to operate the machine while reducing the likelihood of malfunctions or breakdowns



__ deburring and edge rounding with an abrasive contact roller and cross belt system