

DM1100 ZC EVO

/ DEBURRING AND EDGE ROUNDING MACHINE

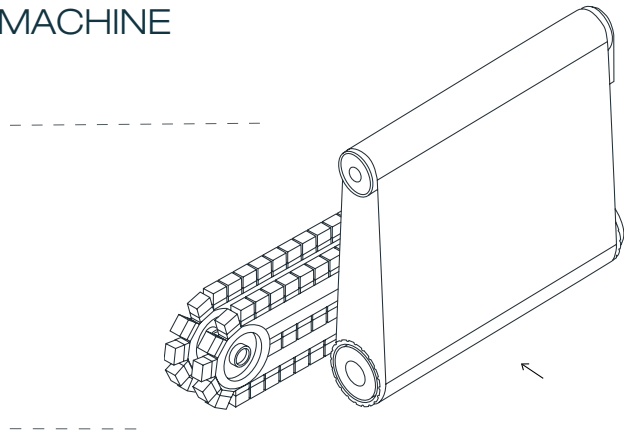

TECHNICAL SPECIFICATIONS

working capacity (mm)	1100x120
feeding speed (m/min)	0.9-13
abrasive belt speed (m/s)	8-22
crossbelt speed (m/s)	2-8
feeding motor (kW)	0.25
abrasive belt dimensions (mm)	1100x2200
abrasive + crossbelt motor (kW)	18.5 + 3 (2x)
consumption (A)	43
dimensions (mm)	2490x2220x2280
weight (kg)	3400

DEMONSTRATION VIDEO



OVERVIEW

__ One large deburring contact roller (Ø240mm) combined with two cross belts mounted with abrasive blocks running in opposite directions

__ Integrated touchscreen for easy monitoring of settings and alarms

__ EVO design with interior lightning, generous space for maintenance access and cleaning

__ strong edge rounding on parts down to 50x50mm



__ touchscreen control panel for automated and motorized adjustments with machine statistics and errors



__ features a powerful deburring and edge rounding stations

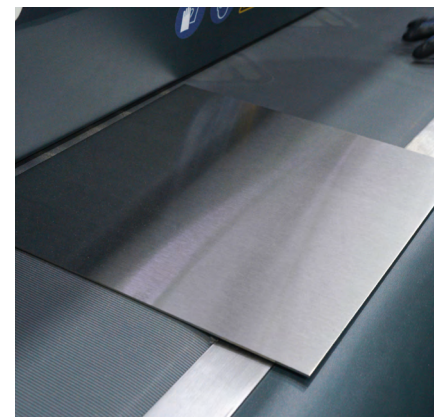

__ special wide belt programs: deburring or surface finishing