

DM1600 ZC EVO

/ DEBURRING AND EDGE ROUNDING MACHINE

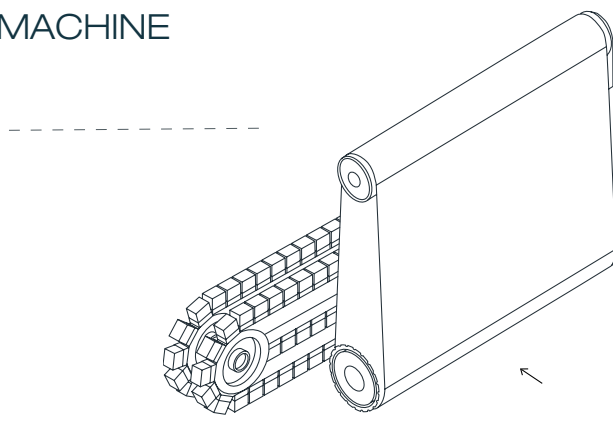

TECHNICAL SPECIFICATIONS

working capacity (mm)	1600x120
feeding speed (m/min)	0.9-13
abrasive belt speed (m/s)	8-22
crossbelt speed (m/s)	2-8
feeding motor (kW)	0.75
abrasive belt dimensions (mm)	1600x2200
abrasive + crossbelt motor (kW)	22 + 4 (2x)
consumption (A)	65
dimensions (mm)	2830x2250x2250
weight (kg)	4860

DEMONSTRATION VIDEO



OVERVIEW

__ One large deburring contact roller (Ø240mm) combined with two cross belts mounted with abrasive blocks running in opposite directions

__ Integrated touchscreen for easy monitoring of settings and alarms

__ Increased capacity with larger table with 1600mm width

__ EVO design with interior lightning, generous space for maintenance access and cleaning



__ grinding laser burrs and rounding the edges in one single step: high performance on all edges and also on internal holes



__ this model with 1600mm can operate more metal parts at the same time increasing working productivity

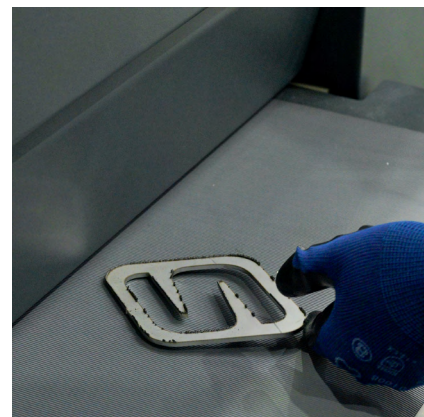

__ excelent work on small parts down to 50x50mm