

DM1600 C

/ EDGE ROUNDING MACHINE

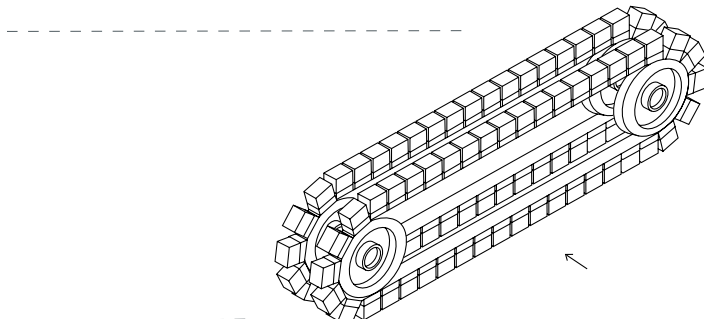

DEMONSTRATION VIDEO



OVERVIEW

__ Two cross belts mounted with abrasive blocks run in opposite directions, completing edge rounding on the complete area of the part

__ DM1600 C can edge round parts with plastic foil, keeping the original finishing and assuring the work purely on the edges

AVAILABLE ACCESSORIES

__ Parts return system improves productivity on small parts or double sided operation (option)

__ Dust extractor

TECHNICAL SPECIFICATIONS

working capacity (mm)	1600X50
feeding speed (m/min.)	0.6-3.2
crossbelt speed (m/s)	2-8
crossbelt motor (kW)	4 (2x)
total power (kW)	8
consumption (A)	18
dimensions (mm)	2090x2710x1940
weight (kg)	1850

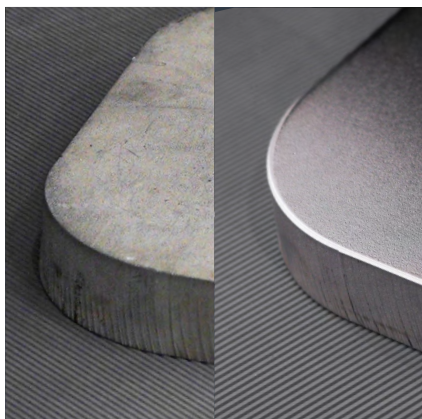

__ stainless-steel part before and after edge rounding



__ Greater productivity on small parts



__ optimized for large workpieces up to 1600mm wide